



2-PC. SCREWED END BALL VALVE

2006SD

FEATURES



- Full port, 1/4"~3" (DN8~DN80)
- W.P. : 1000 WOG (PN63)
- W.T. : -20°C~200°C (-4°F~392°F)
- Investment casting
- Blow-out proof stem
- Live-loading design
- Anti-static device
- Locking device
- ISO 5211 Direct mounting pad
- ISO 15848 fugitive emission approved (option)
- Automation accessories (option)
- Thread type : ASME B1.20.1 (NPT)
DIN2999 & BS21
ISO/1 & EN10226

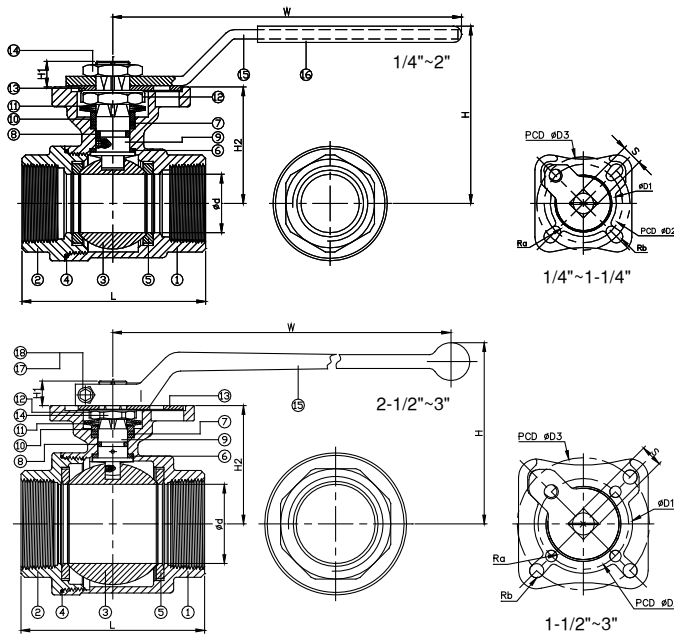

ITEM	PARTS	MATERIAL	
1	BODY	ASTM A351-CF8M	ASTM A216-WCB
2	CAP		
3	BALL	ASTM A351-CF8M	
4	SEAL	PTFE	
5	SEAT	PTFE / RTFE	
6	THRUST WASHER	PTFE	
7	PACKING	PTFE	
8	O-RING	VITON	
9	STEM	ASTM A276-316	
10	GLAND RING	AISI 304	
11	BELLEVILLE WASHER	AISI 301	
12	LOCKING WASHER	AISI 304	
13	STOPPER	AISI 304	
14	STEM NUT	AISI 304	
15	HANDLE	STAINLESS STEEL	
16	HANDLE SLEEVE	PVC	
17	BOLT	AISI 304	
18	NUT	AISI 304	

DN	d	L	H	H1	H2	W	S	D1	D2	D3	Ra	Rb	Torque (N-M)	Weight (kg)
8	11.6	58	62	8	36.4	113.5	9	31	36	42	2.75	2.75	5.5	0.4
10	12.7	58	62	8	36.4	113.5	9	31	36	42	2.75	2.75	5.5	0.4
15	15	58	62	8	36.4	113.5	9	31	36	42	2.75	2.75	5.5	0.4
20	20	65.6	65	9	39.2	113.5	9	31	36	42	2.75	2.75	7.5	0.5
25	25	78.7	76	11	48.7	140	11	35.5	42	50	2.75	3.5	11	0.8
32	32	90	81.5	11	54.2	140	11	35.5	42	50	2.75	3.5	15	1.2
40	38	105	103	11.5	65.7	172	14	56	50	70	3.5	4.5	20	2
50	50	124	111.5	11.5	75.5	172	14	56	50	70	3.5	4.5	40	2.9
65	63	146.2	141	20.5	91.5	310	17	76	70	102	4.5	5.5	60	6
80	76	163.7	150	20.5	100.75	310	17	76	70	102	4.5	5.5	85	7.2

unit:mm

NPS	d	L	H	H1	H2	W	S	D1	D2	D3	Ra	Rb	Torque (in-lb)	Weight (lb)
1/4"	0.46	2.28	2.44	0.31	1.43	4.47	0.35	1.22	1.42	1.65	0.11	0.11	48.7	0.9
3/8"	0.5	2.28	2.44	0.31	1.43	4.47	0.35	1.22	1.42	1.65	0.11	0.11	48.7	0.8
1/2"	0.59	2.28	2.44	0.31	1.43	4.47	0.35	1.22	1.42	1.65	0.11	0.11	48.7	0.8
3/4"	0.79	2.58	2.56	0.35	1.54	4.47	0.35	1.22	1.42	1.65	0.11	0.11	66.4	1
1"	0.98	3.1	2.99	0.43	1.92	5.51	0.43	1.4	1.65	1.97	0.11	0.14	97.4	1.8
1-1/4"	1.26	3.54	3.21	0.43	2.13	5.51	0.43	1.4	1.65	1.97	0.11	0.14	132.8	2.7
1-1/2"	1.5	4.13	4.06	0.45	2.59	6.77	0.55	2.2	1.97	2.76	0.14	0.18	177	4.4
2"	1.97	4.88	4.39	0.45	2.97	6.77	0.55	2.2	1.97	2.76	0.14	0.18	354	6.4
2-1/2"	2.48	5.76	5.55	0.81	3.6	12.2	0.67	2.99	2.76	4.02	0.18	0.22	531	13.2
3"	2.99	6.44	5.91	0.81	3.97	12.2	0.67	2.99	2.76	4.02	0.18	0.22	752.3	15.9

unit:in