



# 3-PC. SOCKET WELD END BALL VALVE

# 2011D

## FEATURES



- Full port, 1/4"~2" (DN8~DN50)
- W.P. : 1000 WOG (PN63)
- W.T. : -20°C~200°C (-4°F~392°F)
- Investment casting
- Blow-out proof stem
- Live-loading design
- Anti-static device
- Locking device
- ISO 5211 Direct mounting pad
- Length conform to DIN 3202/4-M3
- ISO 15848 fugitive emission approved (option)
- Automation accessories (option)
- Socket weld ends conform to ANSI B16.11 & DIN 3239 part2

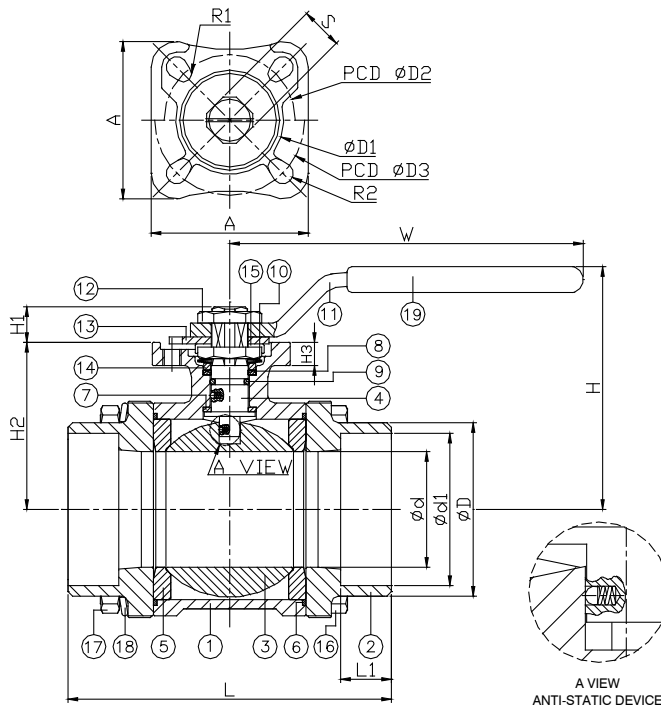

ITEM	PARTS	MATERIAL	
1	BODY	ASTM A351-CF8M	ASTM A216-WCB
2	CAP		
3	BALL	ASTM A351-CF8M	
4	STEM	ASTM A276-316	
5	SEAT	PTFE / RTFE	
6	SEAL	PTFE	
7	THRUST WASHER		
8	PACKING	VITON	
9	O-RING		
10	BELLEVILLE WASHER	AISI 301	
11	HANDLE	STAINLESS STEEL	
12	STEM NUT	AISI 304	
13	LOCKING PAD		
14	GLAND RING		
15	LOCKING WASHER		
16	BOLT		
17	NUT	PVC	
18	SPRING WASHER		
19	HANDLE SLEEVE		

DN	d	d1	D	L	L1	H	H1	H2	H3	W	S	A	D1	D2	D3	R1	R2	ISO 5211	Torque (N-M)
8	8	14.4	22	55	11	63	8	40.3	6.5	120	9	42	31	36	42	2.75	2.75	F03/F04	3.6
10	10	17.9	22	60	11	63	8	40.3	6.5	120	9	42	31	36	42	2.75	2.75	F03/F04	3.6
15	15	22	29	75	10	63	8	40.3	6.5	120	9	42	31	36	42	2.75	2.75	F03/F04	3.6
20	20	27.5	35	80	13	69	9	45	6.5	120	9	42	31	36	42	2.75	2.75	F03/F04	6.1
25	25	34.2	42	90	13	76	10	47.5	7.5	148	11	50	35.5	42	50	2.75	3.5	F04/F05	9.9
32	32	43	52	110	13	84	11	55.5	7.5	148	11	50	35.5	42	50	2.75	3.5	F04/F05	15.6
40	38	49	62	120	13	99	12	65.3	9	178	14	70	56	50	70	3.5	4.5	F05/F07	22
50	50	61	75	140	16	108	12	73	9	178	14	70	56	50	70	3.5	4.5	F05/F07	26.8

unit:mm

NPS	d	d1	D	L	L1	H	H1	H2	H3	W	S	A	D1	D2	D3	R1	R2	ISO 5211	Torque (in-lb)
1/4"	0.31	0.57	0.87	2.17	0.43	2.48	0.31	1.59	0.26	4.72	0.35	1.65	1.22	1.42	1.65	0.11	0.11	F03/F04	31.9
3/8"	0.39	0.7	0.87	2.36	0.43	2.48	0.31	1.59	0.26	4.72	0.35	1.65	1.22	1.42	1.65	0.11	0.11	F03/F04	31.9
1/2"	0.59	0.87	1.14	2.95	0.39	2.48	0.31	1.59	0.26	4.72	0.35	1.65	1.22	1.42	1.65	0.11	0.11	F03/F04	31.9
3/4"	0.79	1.08	1.38	3.15	0.51	2.72	0.35	1.77	0.26	4.72	0.35	1.65	1.22	1.42	1.65	0.11	0.11	F03/F04	54
1"	0.98	1.35	1.65	3.54	0.51	2.99	0.39	1.87	0.3	5.83	0.43	1.97	1.4	1.65	1.97	0.11	0.14	F04/F05	87.6
1-1/4"	1.26	1.69	2.05	4.33	0.51	3.31	0.43	2.19	0.3	5.83	0.43	1.97	1.4	1.65	1.97	0.11	0.14	F04/F05	138.1
1-1/2"	1.5	1.93	2.44	4.72	0.51	3.9	0.47	2.57	0.35	7.01	0.55	2.76	2.2	1.97	2.76	0.14	0.18	F05/F07	194.7
2"	1.97	2.4	2.95	5.51	0.63	4.25	0.47	2.87	0.35	7.01	0.55	2.76	2.2	1.97	2.76	0.14	0.18	F05/F07	237.2

unit:in