



2-PC. SCREWED END BALL VALVE 2006W-A



FEATURES

- Full port
- W.P. : 1/4"~2" -2000 WOG (PN150)
 2-1/2"~3" -1500 WOG (PN100)
- W.T. : -20°C~200°C (-4°F~392°F)
- Investment casting
- Blow-out proof stem
- Anti-static device (option)
- Locking device
- Seal welded ends
- Thread type : ASME B1.20.1 (NPT)
 DIN2999 & BS21
 ISO7/1 & EN10226

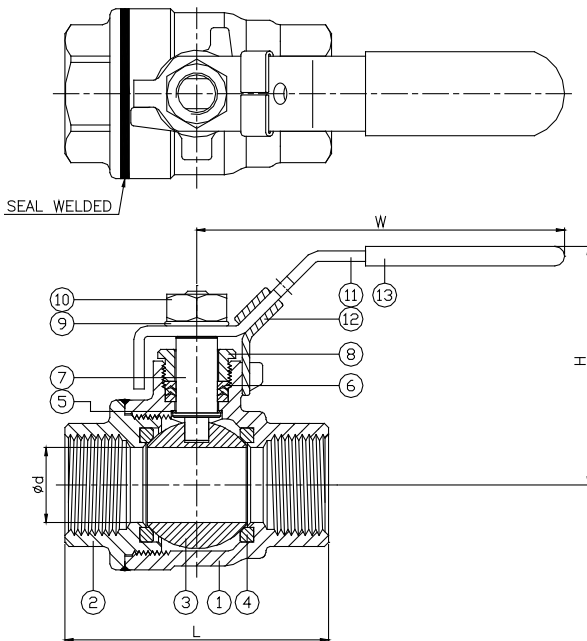

ITEM	PARTS	MATERIAL	
1	BODY	ASTM A351-CF8M	ASTM A216-WCB
2	CAP		
3	BALL	ASTM A351-CF8M	
4	SEAT	RTFE	
5	THRUST WASHER	PTFE	
6	PACKING		
7	STEM	ASTM A276-316	
8	GLAND		
9	SPRING WASHER	AISI 304	
10	NUT		
11	HANDLE	STAINLESS STEEL	
12	LOCKING DEVICE		
13	HANDLE SLEEVE	PVC	

DN	d	L	H	W
8	11.6	51	54.6	101
10	12.5	51	54.6	101
15	15	60	56.5	101
20	20	70	64.3	124
25	25	83	76.7	162
32	32	97	82	162
40	38	110	96.1	183
50	50	134	104.2	183
65	65	167	142.6	245
80	76	192	152.6	245

unit:mm

NPS	d	L	H	W
1/4"	0.46	2.01	2.15	3.98
3/8"	0.49	2.01	2.15	3.98
1/2"	0.59	2.36	2.22	3.98
3/4"	0.79	2.76	2.53	4.88
1"	0.98	3.27	3.02	6.38
1-1/4"	1.26	3.82	3.23	6.38
1-1/2"	1.5	4.33	3.78	7.2
2"	1.97	5.28	4.1	7.2
2-1/2"	2.56	6.57	5.61	9.65
3"	2.99	7.56	6.01	9.65

unit:in