

FEATURES

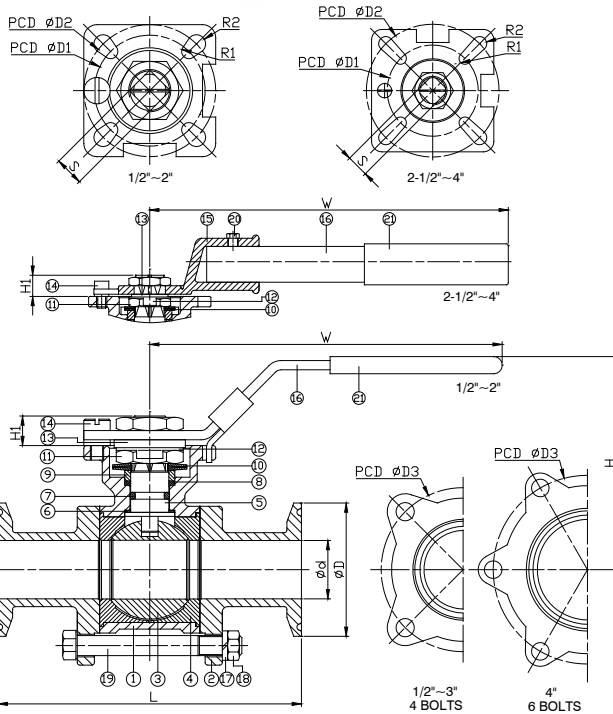

- Clamp end, 1/2"~4" (DN15~DN100)
- Body W.P. : 1000 WOG (PN63)
- Clamp End W.P. : 200 WOG
- W.T. : -20°C~200°C (-4°F~392°F)
- Investment casting
- Blow-out proof stem
- Live-loading design
- Cavity filled seats (option)
- Locking device
- ISO 5211 Direct mounting pad
- DIN 32676-B clamp end - 2013CDA (option)
- Automation accessories (option)



ITEM	PARTS	MATERIAL	
1	BODY	ASTM A351-CF8M	ASTM A351-CF3M
2	CAP		
3	BALL	ASTM A351-CF8M / ASTM A351-CF3M	
4	SEAT	PTFE / TFM 1600	
5	STEM	ASTM A276-316	
6	THRUST WASHER	PTFE	
7	O-RING	VITON	
8	PACKING	PTFE	
9	GLAND RING	AISI 304	
10	BELLEVILLE WASHER	AISI 301	
11	NUT	AISI 304	
12	LOCKING WASHER		
13	FLAT WASHER		
14	STOP PIN		
15	WRENCH BLOCK	STAINLESS STEEL	
16	HANDLE		
17	SPRING WASHER	AISI 304	
18	NUT		
19	BOLT		
20	BOLT	PVC	
21	HANDLE SLEEVE		

DN	d	D	L	H	H1	W	S	D1	D2	D3	R1	R2	Torque (N·M)	Weight (kg)
15	9.6	25.4	90.7	66.2	9	123	9	36	42	45.5	2.75	2.75	5	0.6
20	15.8	25.4	103	67.5	11	123	9	36	42	47	2.75	2.75	7.5	0.7
25	22.1	50.5	115	80.2	11	151.5	11	42	50	57.5	2.75	3.5	11	1.2
40	34.8	50.5	139	98.5	14	182	14	50	70	83	3.5	4.5	16	2.5
50	47.7	64	158	107	14	182	14	50	70	100	3.5	4.5	20	3.6
65	60.3	77.5	197	130.3	17	344	17	70	102	126	4.5	5.5	40	7
80	72.9	91	228	139.3	17	344	17	70	102	148	4.5	5.5	50	9.9
100	97.5	119	241.8	169	22	389	22	102	125	183	5.5	6.5	60	17.1

unit:mm

NPS	d	D	L	H	H1	W	S	D1	D2	D3	R1	R2	Torque (in-lb)	Weight (lb)
1/2"	0.38	1	3.57	2.61	0.35	4.84	0.35	1.42	1.65	1.79	0.11	0.11	44.3	1.4
3/4"	0.62	1	4.06	2.66	0.43	4.84	0.35	1.42	1.65	1.85	0.11	0.11	66.4	1.5
1"	0.87	1.99	4.53	3.16	0.43	5.96	0.43	1.65	1.97	2.26	0.11	0.14	97.4	2.6
1-1/2"	1.37	1.99	5.47	3.88	0.55	7.17	0.55	1.97	2.76	3.27	0.14	0.18	141.6	5.5
2"	1.88	2.52	6.22	4.21	0.55	7.17	0.55	1.97	2.76	3.94	0.14	0.18	177	7.9
2-1/2"	2.37	3.05	7.76	5.13	0.67	13.54	0.67	2.76	4.02	4.96	0.18	0.22	354	15.4
3"	2.87	3.58	8.98	5.48	0.67	13.54	0.67	2.76	4.02	5.83	0.18	0.22	442.5	21.8
4"	3.84	4.69	9.52	6.65	0.87	15.31	0.87	4.02	4.92	7.2	0.22	0.26	531	37.7

unit:in