

FEATURES

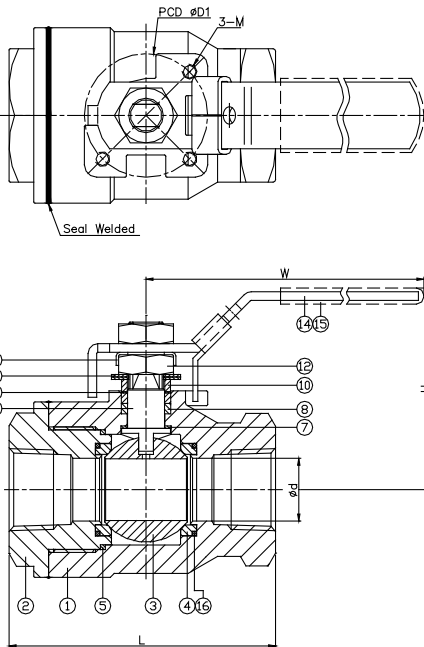

- 1/4"~2" (DN8~DN50)
- W.P. : 6000 WOG (PN420)
- W.T. : -20°C~260°C (-4°F~500°F)
- Investment casting
- Blow-out proof stem
- Anti-static device (option)
- Locking device
- ISO 5211 Mounting pad
- **Seal welded ends**

- Thread type : ASME B1.20.1 (NPT)
DIN2999 & BS21
ISO/1 & EN10226



ITEM	PARTS	MATERIAL	
1	BODY	ASTM A351-CF8M	ASTM A216-WCB
2	CAP		
3	BALL	17-4PH	
4	SEAT	PEEK	
5	SEAL	GRAPHITE	
6	STEM	17-4PH	
7	THRUST WASHER	CTFE	
8	PACKING A	GRAPHITE	
9	PACKING B	CTFE	
10	GLAND	AISI 304	
11	BELLEVILLE WASHER	AISI 301	
12	STEM NUT	AISI 304	
13	LOCK WASHER		
14	HANDLE	STAINLESS STEEL	
15	HANDLE SLEEVE	PVC	
16	O-RING	VITON	

DN	d	L	H	W	D1	M
8 F	9.4	71.1	62.7	107.5	36	M5
10 F	9.4	71.1	62.7	107.5	36	M5
15 F	12.7	81	62.7	107.5	36	M5
20 F	19	96	67.4	130	42	M5
25 F	25.4	108	79.7	166.5	50	M6
32 F	32	119.9	87.2	166.5	50	M6
40 F	38.1	130	110.4	219.5	70	M8
50 S	38.1	150.1	110.4	219.5	70	M8

F: Full Port S: Standard Port

unit: mm

NPS	d	L	H	W	D1	M
1/4" F	0.37	2.8	2.47	4.23	1.42	M5
3/8" F	0.37	2.8	2.47	4.23	1.42	M5
1/2" F	0.5	3.19	2.47	4.23	1.42	M5
3/4" F	0.75	3.78	2.65	5.12	1.65	M5
1" F	1	4.25	3.14	6.56	1.97	M6
1-1/4" F	1.26	4.72	3.43	6.56	1.97	M6
1-1/2" F	1.5	5.12	4.35	8.64	2.76	M8
2" S	1.5	5.91	4.35	8.64	2.76	M8

F: Full Port S: Standard Port

unit: in