

FEATURES

- Tube port, 1/2"~4" (DN15~DN100)
- Body W.P. : 1000 WOG (PN63)
- Tube End W.P. : 200 WOG
- W.T. : -20°C~200°C (-4°F~392°F)
- Investment casting
- Blow-out proof stem
- Cavity filled seats (option)
- Locking device
- ISO 5211 Mounting pad

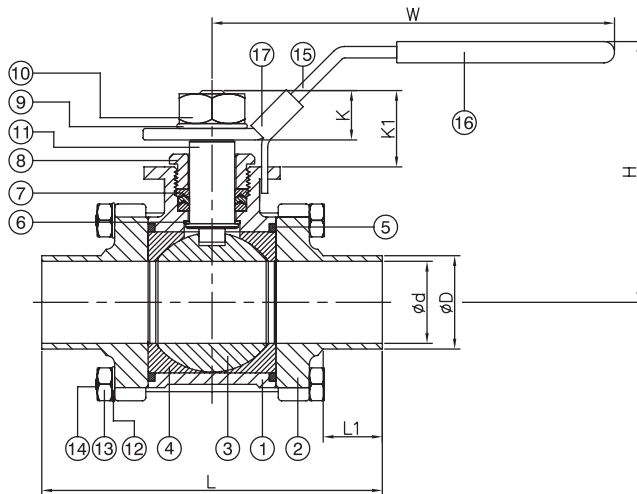
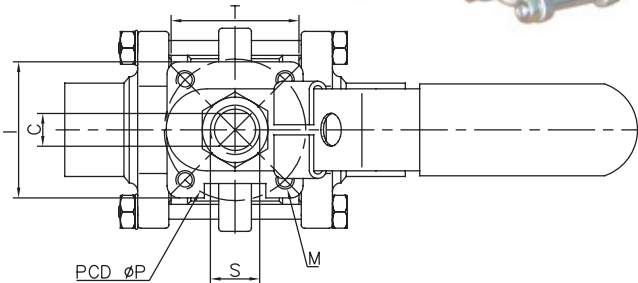

ITEM	PARTS	MATERIAL
1	BODY	ASTM A351-CF8M
2	CAP	
3	BALL	
4	SEAT	PTFE
5	SEAL	
6	THRUST WASHER	AISI 304
7	PACKING	
8	GLAND NUT	AISI 316
9	STEM WASHER	
10	STEM NUT	AISI 304
11	STEM	
12	BOLT WASHER	STAINLESS STEEL
13	NUT	
14	BOLT	PVC
15	HANDLE	
16	HANDLE SLEEVE	STAINLESS STEEL
17	LOCKING DEVICE	

DN	d	D	W	H	L	L1	T	C	I	K	K1	P	M	S	Torque For Cavity Filler Seat (N-M)	Weight (kg)
15	9.6	12.7	141.2	63.5	90.7	20	26.7	6.5	37	13	18	36	M5	M10	3.6	0.7
20	15.8	19.1	141.2	66.6	103	22.5	33	6.5	37	13	18.7	36	M5	M10	5.1	0.9
25	22.1	25.4	141.2	69.4	115	25	38	6.5	42	13	18	42	M5	M10	8.1	1.2
40	34.8	38.2	188.3	100.6	140	25	54	8.5	50	19.5	30	50	M6	M12	19.5	2.6
50	47.7	50.8	188.3	110.6	158	25	69	8.5	50	19.5	29	50	M6	M12	26	4
65	60.3	63.5	260	139.2	197	25	85	12	72	26	37.7	70	M8	3/4"W	52	8.4
80	72.9	76.4	260	148.2	228	25	101.6	12	72	26	38.2	70	M8	3/4"W	58.5	13.5
100	97.5	101.7	295	175	241.8	25	121.8	16	94	35	52	102	M10	1"W	84.5	19.5

unit:mm

NPS	d	D	W	H	L	L1	T	C	I	K	K1	P	M	S	Torque For Cavity Filler Seat (in-lb)	Weight (lb)
1/2"	0.38	0.5	5.56	2.5	3.57	0.79	1.05	0.26	1.46	0.51	0.71	1.42	M5	M10	32.2	1.6
3/4"	0.62	0.75	5.56	2.62	4.06	0.89	1.3	0.26	1.46	0.51	0.74	1.42	M5	M10	44.9	2.1
1"	0.87	1	5.56	2.73	4.53	0.98	1.5	0.26	1.65	0.51	0.71	1.65	M5	M10	71.3	2.6
1-1/2"	1.37	1.5	7.41	3.96	5.51	0.98	2.13	0.33	1.97	0.77	1.18	1.97	M6	M12	172.6	5.7
2"	1.88	2	7.41	4.35	6.22	0.98	2.72	0.33	1.97	0.77	1.14	1.97	M6	M12	230.1	8.9
2-1/2"	2.37	2.5	10.24	5.48	7.76	0.98	3.35	0.47	2.83	1.02	1.48	2.76	M8	3/4"W	460.2	18.6
3"	2.87	3.01	10.24	5.83	8.98	0.98	4	0.47	2.83	1.02	1.5	2.76	M8	3/4"W	517.8	29.8
4"	3.84	4	11.61	6.89	9.52	0.98	4.8	0.63	3.7	1.38	2.05	4.02	M10	1"W	747.9	43

unit:in